

Edgeless Clarion

Permanently tensioned projection screen with no visible frame

SUBMITTAL

TECHNICAL INFO

Please check all appropriate selections and attach room schedule with verified dimensions.

Specifications

QUANTITY: _____ SIZE: _____ h. x _____ w. (overall size)

designed for permanent wall mounting. Extruded aluminum base frame, equipped with snaps set on 6" (152mm) centers. Viewing surface shall wrap around frame, concealing it completely, and attach to rear side.

Matt White XT1000V and Grey XH600V viewing surfaces are certified to GREENGUARD standards for low chemical emissions into indoor air during product usage. For more information, visit ul.com/gg.

Viewing surfaces have reinforced black webbing on all four sides with snaps to fit base frame. Webbing completely concealed behind frame. Frame equipped with mounting flange that mates with wall brackets.

Downloadable 3-part specifications: available at www.draperinc.com

Please note: Dimensions of rollers, operators and hardware at manufacturer's discretion.



Select Viewing Surface:

TECVISION Premium Optical Surface

Choose TecVision® surface:

- XH700X Grey (0.7 gain) Certified
- XH800X ALR (0.8 gain) Certified
- XH900X ALR (0.9 gain) Certified
- XH1200X Grey (1.2 gain) Certified
- MS1000X ALR (1.0 gain) Certified
- CS1100X ALR (1.1 gain) Certified
- XT1000X White (1.0 gain) Certified
- XT1100X White (1.1 gain) Certified
- XT1300X White (1.3 gain) Certified
- XT1600X White (1.6 gain) Certified
- Other

I want the above **TECVISION** surface perforated.

Choose standard viewing surface:

- Matt White XT1000VB* (1.0 gain): GREENGUARD Gold certified
- Grey XH600V (0.6 gain) (Thru 9' x 12'): GREENGUARD Gold certified
- Clearsound Nanoperf XT1000V (1.0 gain)
- Other

Dimensions and Data

16:10 Format

Nominal Diagonal	Image Area (H x W)	Overall Size	Net Wt. (lbs.)	Quantity
85"	45" x 72"	45" x 72"	20	
94"	50" x 80"	50" x 80"	21	
109"	57 1/2" x 92"	57 1/2" x 92"	23	
113"	60" x 96"	60" x 96"	24	
123"	65" x 104"	65" x 104"	26	

16:9 HDTV Format

Nominal Diagonal	Image Area (H x W)	Overall Size	Net Wt. (lbs.)	Quantity
82"	40 1/2" x 72"	40 1/2" x 72"	20	
92"	45" x 80"	45" x 80"	21	
106"	52" x 92"	52" x 92"	23	
110"	54" x 96"	54" x 96"	24	
119"	58" x 104"	58" x 104"	26	
133"	65" x 116"	65" x 116"	28	

4:3 NTSC VIDEO Format

Nominal Diagonal	Image Area (H x W)	Overall Size	Net Wt. (lbs.)	Quantity
90"	54" x 72"	54" x 72"	21	
100"	60" x 80"	60" x 80"	23	
120"	72" x 96"	72" x 96"	27	
132"	78" x 104"	78" x 104"	30	

Custom Size (available up to 168" x 168")

Also available in 1:85-1 and 15:9 Formats. Contact Draper.				



Draper, Inc. | 411 S. Pearl St. Spiceland, IN 47385
draperinc.com | 765.987.7999 | 800.238.7999

© 2024 All Rights Reserved | FORM: Clarion_Edgeless_Sub24

PROJECT: _____

ARCHITECT: _____

CONTRACTOR: _____

SUPPLIER: _____

DATE: _____ REVISED: _____

Dimensions

Side View

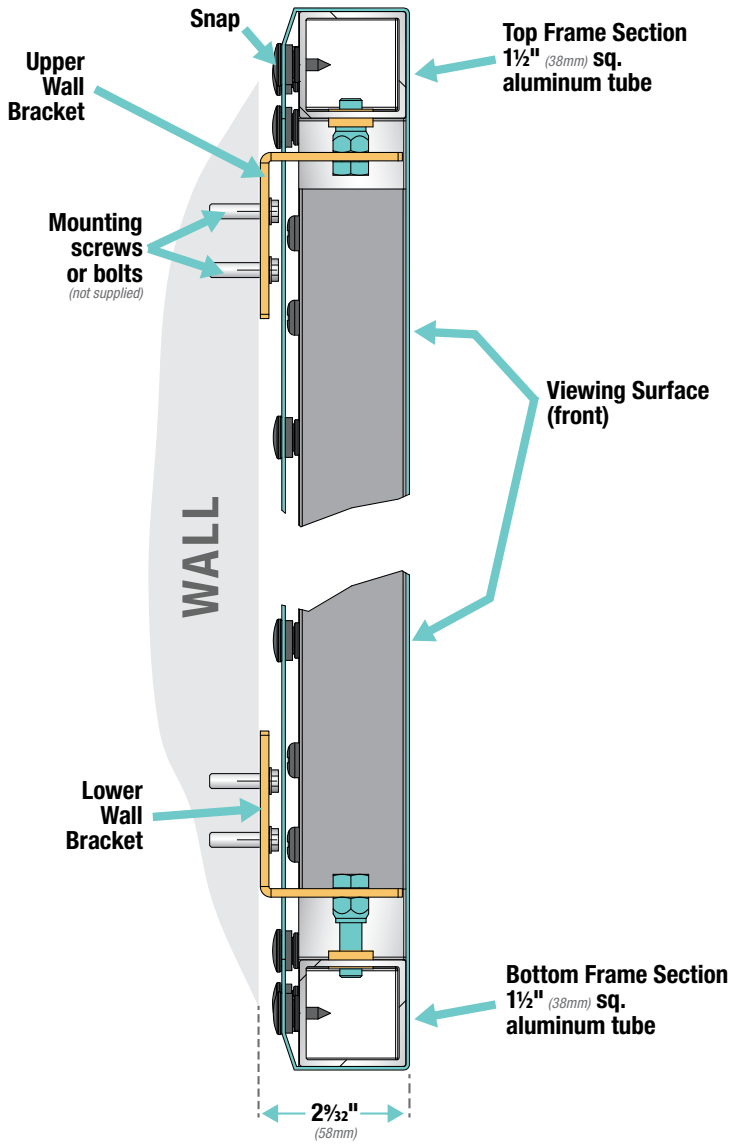

Optional Fly Brackets

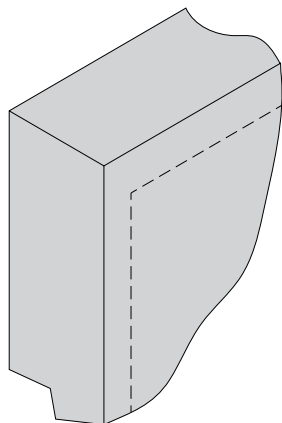
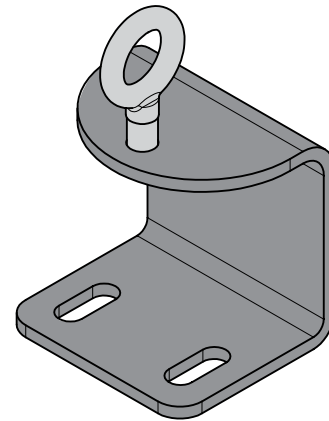
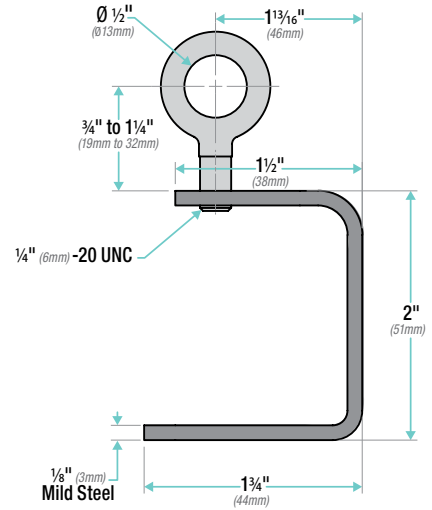

Corner Detail

PROJECT: _____

ARCHITECT: _____

CONTRACTOR: _____

SUPPLIER: _____

DATE: _____ REVISED: _____