

Installation & Operating Instructions

EZ-503285 / 503280 Electric Backstop Winch

DRAPER

⚠ Caution ⚠

- ① As with any lifting device, the installation shall be made only by persons suitably experienced and qualified for work on hoisting equipment, in accordance with local requirements.
- ② The electrical supply and connection to the winch shall be made in accordance with local electrical code and by qualified personnel.
- ③ The instructions address the areas of proper mounting, rope installation, wiring and limit switch adjustment, but they are not intended to cover every aspect of installation of your hoisting system, nor to replace the need for normal good care, workmanship and proper practices on the part of the installer. Read all instructions prior to installation and use.
- ④ This unit is intended for indoor use only.
- ⑤ Use appropriate lock-out and tag-out procedure when installing unit.

Hardware packet includes:

Description	Quantity
Washer, Flat, 1/2" x 1 3/8"	4
Flange Lock	4
Nut, Hex, 1/2"	4
Screw, Hex head, 1/2" x 2 1/2"	4
Screw, Square head, 3/8" x 1/2"	2
Half Clamp, Pipe, 3"	2

Tools needed:

- Twelve point socket 3/4" six or Socket drive
- 3/4" combination open/box end wrench
- 3/8" eight point socket
- 0-100 ft lb torque wrench
- Center punch & drive hammer
- 3/8" twist drill
- Cordless drill motor
- #3 Phillips screw driver

The clamps provided are designed for 4" tube (4" outside diameter) or 3" pipe (3 1/2" outside diameter).

- ① The basketball backstop must be in its down position for installation of the winch. Locate the installation position of the winch. It is important that the winch be located a proper distance from the closest pulley or attachment point. This is based on the total travel distance of the cable pulled by the winch. Generally speaking the greater the amount of cable drawn, the greater the distance needs to be. For any length of cable, the formula is 4 inches of offset per foot of cable drawn. (See winch drum chart).

Winch Drum Chart			
Cable payout in feet	# turns	IN. Linear travel on drum	Min drum to pulley distance
10	8.6	2.4	48
15	12.9	3.6	60
20	17.1	4.8	72
25	21.4	6.0	86
30	25.7	7.2	103

Technical Information

WEIGHT	68 LBS
LENGTH	22.85 in
WIDTH	12.75 in
HEIGHT	13.45 in
POWER VOLTAGE	120 AC
CURRENT	11.5 FLA
FREQUENCY	60 HZ
DUTY	Intermittent 10 min.
CAPACITY	1000 LBS Max
TRAVEL SPEED	35 Feet 9 ft/min Max

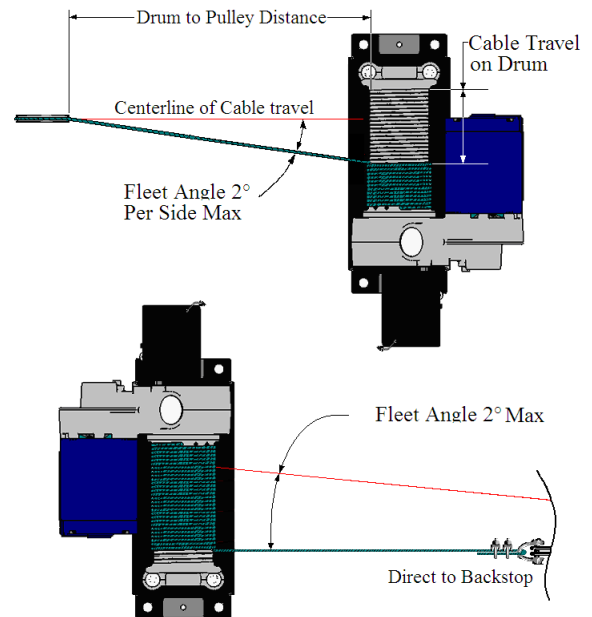
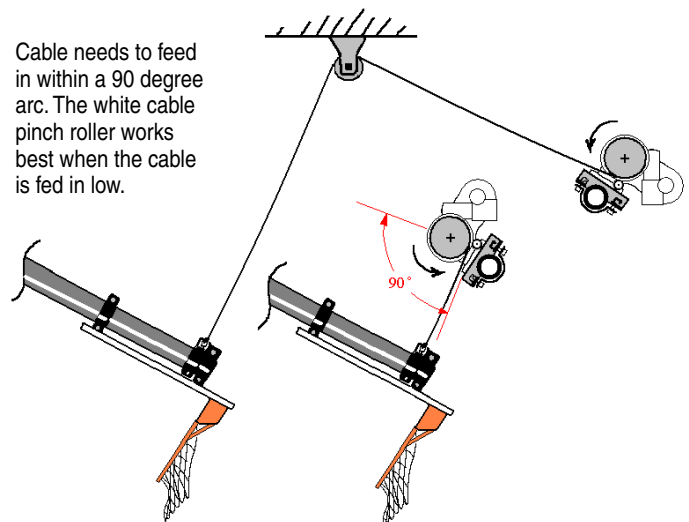

Figure 1

Determine the installation angle of the winch. During the full range of motion of the backstop, the cable must not ever rub on any part of the winch or backstop structure.



DRAPER

411 S. Pearl St., Spiceland, IN 47385 USA ■ 765-987-7999
www.draperinc.com ■ fax 765-987-7142

Copyright ©2016 Draper Inc. Form EZ-503085-ElectricWinch_Inst16 Printed in U.S.A.

If you encounter any difficulties installing or servicing your EZ Backstop Winch, call your dealer or Draper, Inc., Spiceland, Ind., (765) 987-7999 or fax (765) 987-7142.

- ② Attach one half of each pipe clamp to the base plate of the winch as shown. This is so that you can place the winch on the mounting structure pipe and have the clamps handy for assembly.

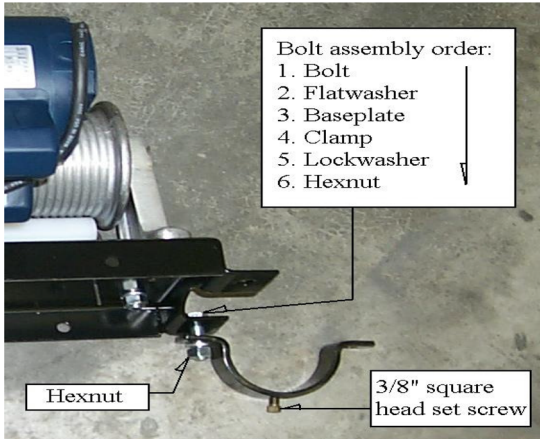

Figure 2

- ③ Insert the second set of bolts and washers into clamps and base plate.



Figure 3

- ④ Position the winch and hand tighten the bolts so that the winch will remain in position on the pipe.
- ⑤ Mark pipe for set screw hole. Use the $\frac{3}{8}$ " 8 point socket and drive handle to tighten the $\frac{3}{8}$ " square head set screw against the pipe enough to dent the paint on the pipe.
- ⑥ Loosen the clamp bolts enough that the winch can be rotated and moved about 3" to one side.
- ⑦ Use center punch to mark and indent the centers of where the set screw upset the paint on the mounting pipe. This is so that you can drill an index hole in the pipe to prevent rotation of the hoist.

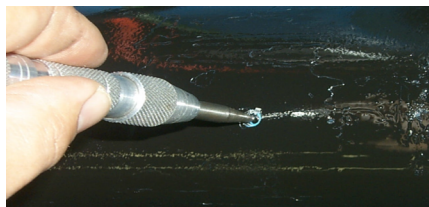

Figure 4

- ⑧ Drill the pipe with the $\frac{3}{8}$ " drill so that the holes pierce completely into the interior of the pipe.



Figure 5

- ⑨ Re-position the winch clamps over the holes in the pipe and tighten the square head set screws into the holes in the pipe. Torque the set screws to 18 ft lbs.
- ⑩ Tighten the four half inch hex bolts that hold the clamps to the base plate. Torque the nuts on the hex bolts to 35 ft lbs.

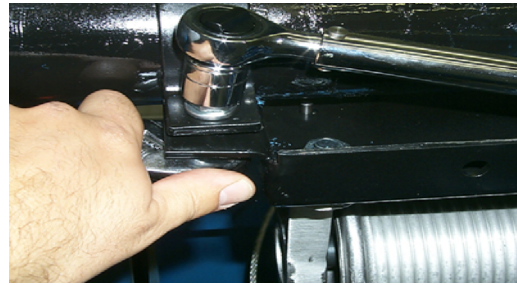

Figure 6

- ⑪ Connect winch to building or temporary power source.
- ⑫ If necessary, route cable as shown on backstop drawings.
- ⑬ Use only $\frac{1}{4}$ " Galvanized Steel, 7 x 19 stranded wire Rope (per MILDTL-83420 or Equivalent). Assure the cable set screws are loosened enough to allow the cable to insert fully into the drum. Insert cable into socket in drum, and push through until the end is exposed on the opposite side of the drum.

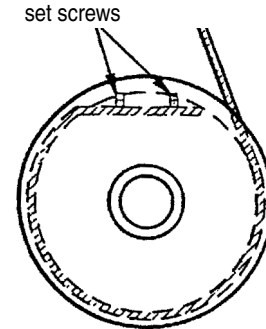

Figure 7

- ⑭ Torque both set screws to 7 ft lbs.



Figure 8

- ⑮ Wind a minimum of two safety wraps of cable on the drum.
- ⑯ The cable must wind onto the drum following the grooves on the drum. It will only wind properly on the drum in one direction.

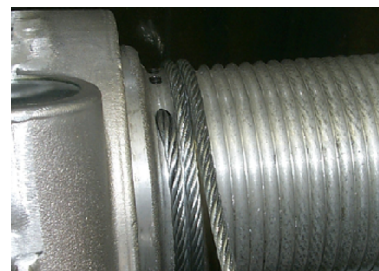

Figure 9

WARNING: Cable winding on drum poses a severe pinch hazard! Use extreme caution while installing cable. Do not guide cable onto drum with hands; use proper tools. Do not damage or nick the cable in the process of winding it onto the drum. Do not wear loose clothing, long hair, jewelry, etc. When installing cable on drum, ensure that the opposite end of the cable is free. Do not attach cable to backstop until the hoist unit is installed and the cable wound on the drum.

⑰ Attach far end of cable to the backstop. Leave 1"-2" of slack in cable.

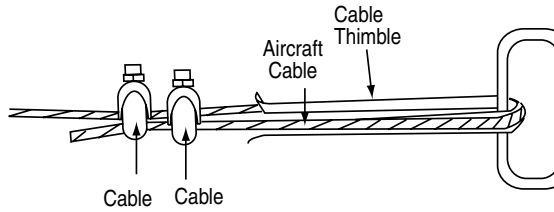

Figure 10

⑱ Lock out electrical power.

WARNING: HIGH VOLTAGE! Setting the limit switches is a hazardous operation. To set the limit switches you must access the winch while the cable is installed. Lock out and tag the circuit breaker for this unit before adjusting the limit wheel settings. This prevents electric shock, and injury due to unexpected winch movement.

⑲ Set limit switches. Loosen the retaining screw and remove the limit Box Cover.



Figure 11

⑳ Press the black index locking bar away from the down direction index wheel so it can rotate freely. Rotate the wheel until the switch "clicks" indicating that the switch is active.

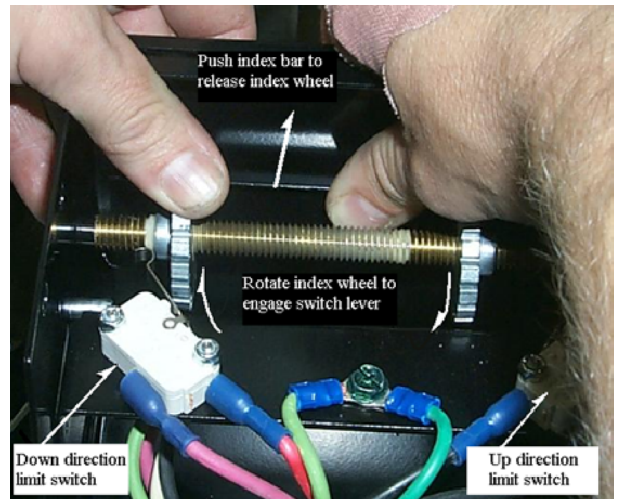
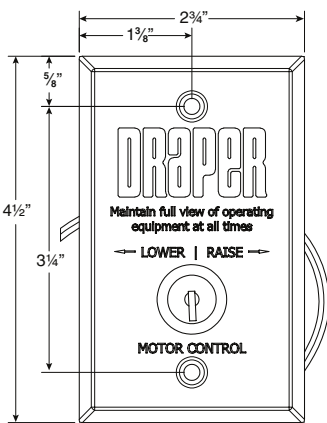
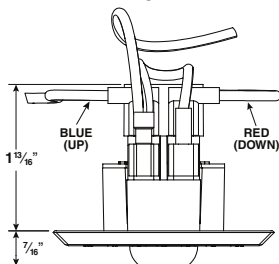

Figure 12

- ⑳ Unlock and restore electrical power. Twist the key switch in the down direction to verify the down switch setting. The winch should not move.
 - ㉑ Lock out electrical power and adjust the down direction wheel as necessary to obtain desired setting. The cable should have 1"-2" of slack in the down position.
 - ㉒ Estimate the amount of cable drawn when the backstop travels from the deployed (down) position to the stowed (up). The number of feet of cable is roughly equivalent to the number of threads between the two index wheels.
 - ㉓ Set the Up Direction index wheel so that the two wheels are the same number threads apart as the cable travel in feet.
 - ㉔ Unlock and restore power.
 - ㉕ Operate the winch to raise the backstop to its stowed position. Since each rotation of the drum is about 14.2 inches, the winch should stop short of desired stowage; the drum rotates at the same speed as the limit shaft.
- WARNING: Always directly observe the movement of the backstop whenever operating, watching for mechanical interference!**
- ㉖ Remember to appropriately lock and unlock the electrical power. Adjust the up direction limit switch until the backstop is set.
 - ㉗ Place the cover on the limit box and secure the screw with a screwdriver.



FRONT



TOP

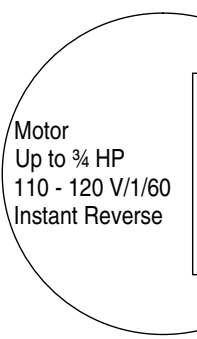

Wiring Diagram

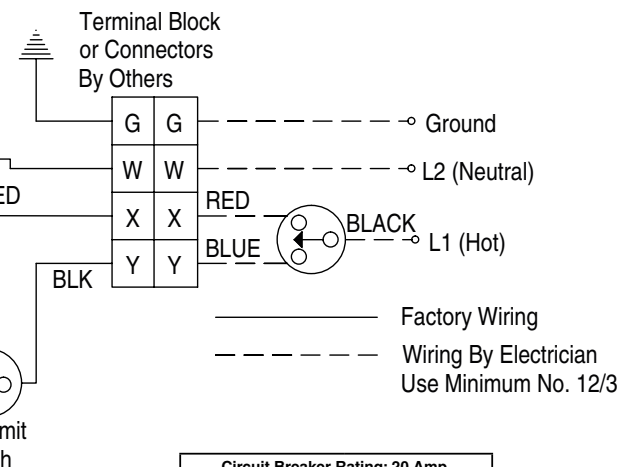

Please Note: Key switch supplied only with 503285.

Circuit Breaker Rating: 20 Amp.	
Fused Circuit Rating: 20 Amp.	
Full Load Amperage: 9.8 Amp	
Recommended Minimum Wire Size	
90' Maximum Run	12 AWG
91' to 140' Run	10 AWG
140' to 225' Run	8 AWG
Wire size recommendations based on 3/4 HP Motor, 3% voltage drop, copper wire and are calculated using standard wire size calculation methods	
Size of wall masonry boxes required for single and key switches	
All Boxes: 2" (w) x 3 3/4" (h) x 2 1/2" (d)	

Dimensions

