

Installation Instructions

Electric Gym Divider/Practice Cage Winch

Caution

- ① As with any lifting device, the installation shall be made only by persons suitably experienced and qualified for work on hoisting equipment, in accordance with local requirements.
- ② The electrical supply and connection to the winch shall be made in accordance with local electrical code and by qualified personnel.
- ③ These instructions address the areas of proper mounting, rope installation, wiring and limit switch adjustment, but they are not intended to cover every aspect of installation of your hoisting system nor to replace the need for normal good care, workmanship and proper practices on the part of the installer.

Mounting Winch

Winch can be provided with a variety of mounting clamps to allow flexibility in mounting the unit. Mounting clamp and hardware size and type will vary according to type of mounting surface and style of curtain, but mounting surface must be adequate to safely sustain loads imposed by curtain system. The architect/building engineer should be consulted to insure mounting surface is adequate. Divider winch can be mounted in virtually any position as it is designed to lift curtain while turning in either direction. Consult project specific drawings for mounting direction and details.

Do not use long extension cords to power winch. To set limit switches prior to connection to permanent power, use a minimum of 14/3 gauge wire, a maximum of 100' to power the winch during installation. Permanent power to winch should be run according to wire size chart shown with wiring diagram. Running winch under poor power/voltage conditions may result in damage to winch and may void the warranty.

Please Note: Do not overtighten U-Bolts if used; overtightening can cause deflection and weakening of the bolts, and damage to the unit.

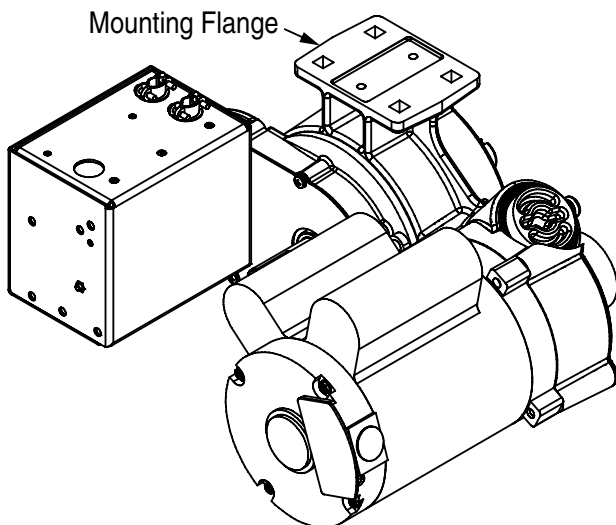

Figure 1

Winch Wiring (see Wiring Diagram on page 2)

Winch is factory wired and comes with a 48" cord pre-attached. Electrician should locate junction box so that 48" cord reaches box with sufficient length to allow for proper connection. Electrician should connect cord to building wiring per wiring diagram (see page 2). Model No. 503091 Plug Kit is available to provide a local disconnect for an electrically operated divider curtain. Plug kit consists of one four-prong NEMA L14-20P twist lock grounded plug, one matching NEMA L14-20 twist lock grounded receptacle and one matching 1/2" deep cover for a 4" electrical box. Plug to be field installed to whip attached to divider winch.

Please Note: The winch limit switches are pre-wired from the factory. Do not test or run winch with the limit switches by-passed or disabled as this may allow over-travel of the limit mechanism and result in damage to the winch. Make certain there is at least one half inch of limit nut travel remaining after the limit switch has tripped to allow the operator time to release the key switch long before an over-travel condition is reached, avoiding damage to the winch, curtain or structure in the rare event of limit switch failure.

Limit Switch Adjustment

⚠CAUTION: Setting the limit switches is a hazardous operation. To set the limit switches you must access the hoist while the cable is installed and observe operation to determine travel direction. Lock out and tag the electrical source prior to making any actual adjustment inside the limit switch box to prevent electric shock and/or injury due to unexpected winch movement.

- ① Remove the limit box cover by loosening limit box cover retaining screw. Cover will slide to one side and hinge open. Cover is on a cable tether to prevent it from falling and damaging the curtain or floor.
- ② Carefully observe the travel of the limit switch index wheels as the winch is operated. Two travel limit switches are provided. Which becomes the upper limit switch and which becomes the lower limit switch depends on the direction of rotation of the winch drum while the curtain is being raised. This is determined by the conditions of each installation. Carefully check which switch is for the upper travel and which is for lower travel before making any adjustments. Failure to do so could result in damage to the winch or curtain system as it may over-travel if wrong switch is adjusted.
- ③ Operate hoist in one direction until desired position is reached or limit switch actuates. If necessary, move index wheel to allow more travel by following steps 4 to 8 below.
- ④ Shut off or disconnect power to winch to prevent chance of electric shock and/or injury due to unexpected winch movement.
- ⑤ Push the index bar toward the electrical box (away from the threaded rod) to disengage index wheel.
- ⑥ Rotate index wheel toward or away from the micro switch as required.
- ⑦ Release index bar ensuring that it engages index wheel.
- ⑧ Turn on or reconnect power to winch and verify travel stops at desired location and repeat steps 4 to 7 as necessary for each direction of travel.
- ⑨ Verify setting in each direction and reattach limit switch box cover.

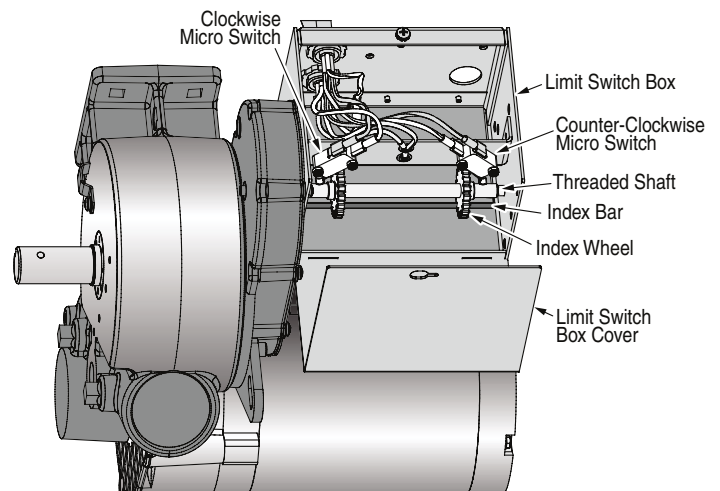

Figure 2

DRAPER

411 S. Pearl St., Spiceland, IN 47385 USA ■ 765-987-7999
www.draperinc.com ■ fax 765-987-7142

Copyright © 2016 Draper Inc. Form GymDividerWinch_Inst16

Printed in U.S.A.

If you encounter any difficulties installing or servicing your Winch, call your dealer or Draper, Inc., Spiceland, Ind., (765) 987-7999 or fax (765) 987-7142.

Dimensions

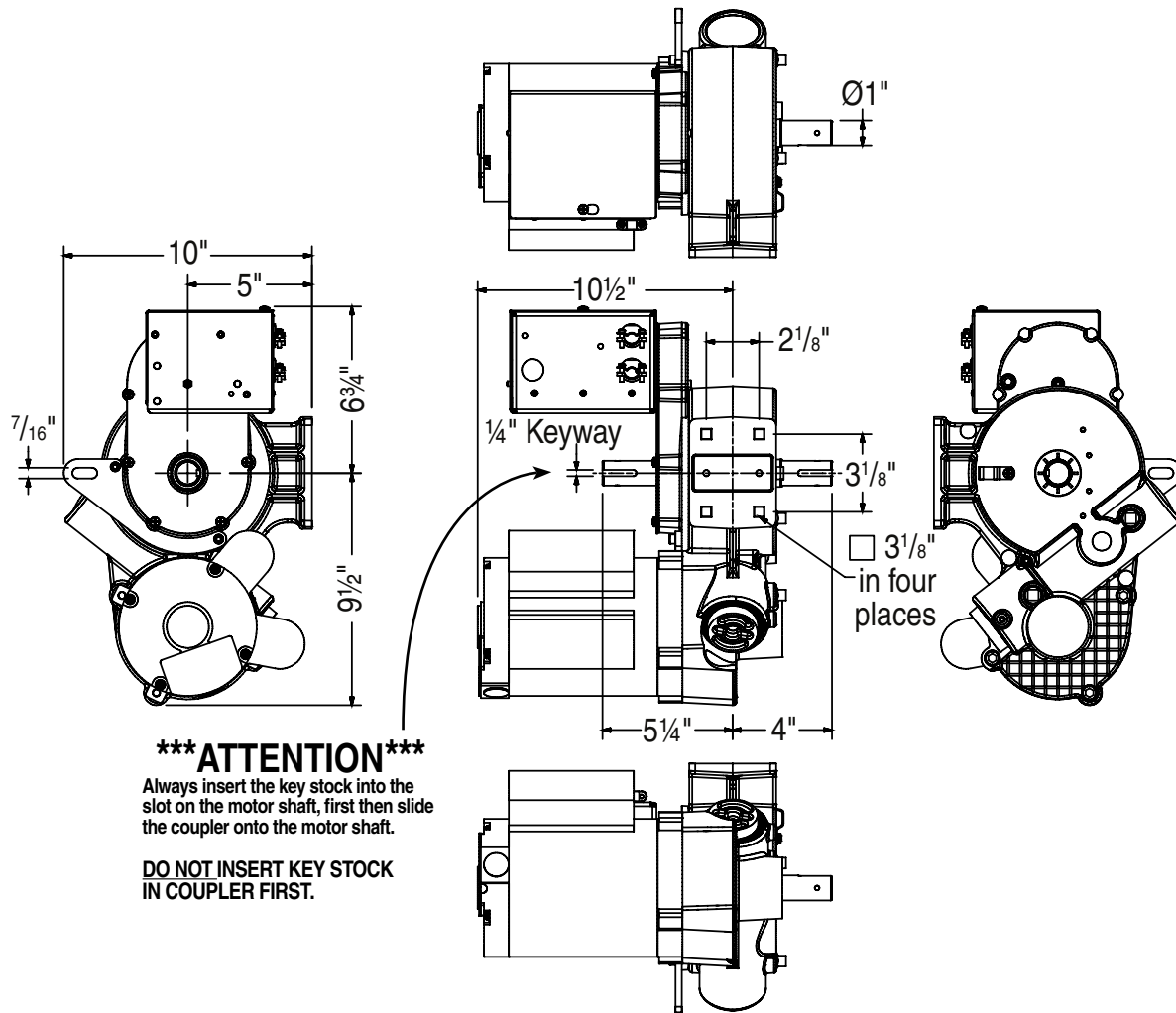

*** ATTENTION ***

Always insert the key stock into the slot on the motor shaft, first then slide the coupler onto the motor shaft.

DO NOT INSERT KEY STOCK IN COUPLER FIRST.

Wiring Diagram

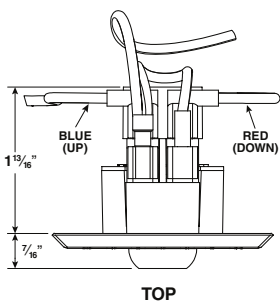
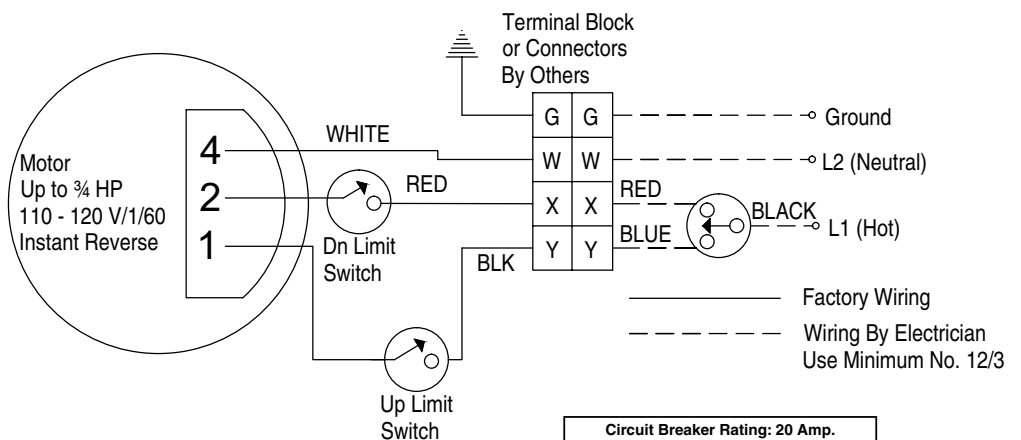
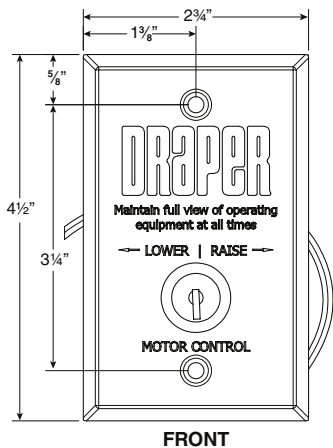

Circuit Breaker Rating: 20 Amp.	
Fused Circuit Rating: 20 Amp.	
Full Load Amperage: 9.8 Amp	
Recommended Minimum Wire Size	
90' Maximum Run	12 AWG
91' to 140' Run	10 AWG
140' to 225' Run	8 AWG
Wire size recommendations based on 3/4 HP Motor, 3% voltage drop, copper wire and are calculated using standard wire size calculation methods	
Size of wall masonry boxes required for single and key switches	
All Boxes: 2" (w) x 3 3/4" (h) x 2 1/2" (d)	