

Single Mat Lifter

Electrically Operated Mat Lifter for Single Wrestling Mat



Specifications—Single Mat Lifter

_____mat lifters shall be #502060, by Draper, Inc., Spiceland, Indiana. Mat lifter construction shall consist of a 20' I-beam frame, with all drive and lifting mechanism enclosed in a sheet metal housing. Unit shall be a three cable system to assure balanced operation. Cables shall be attached to the I-beam frame and attach to the load bar, which shall be connected to fabric slings. Standard lifter, load bar, and sling shall be capable of supporting one standard 45' x 45' wrestling mat (weighing approximately 1 lb./sq. ft.). Mats may be one-piece or in sections placed end to end. Each unit shall consist of a highly efficient hollow bored helical gear direct drive (1.5" diameter) solid key shaft to an instantly reversing 1 HP motor, operating with 208/230/460 volts in 3-phase, including a 7.4 lb fast action brake. Lifting and lowering speed shall be approximately 10 feet per minute. System shall have a custom integrated motion alarm which automatically sounds when system is in motion for safety.

Lifting drums shall be 4" diameter directly coupled to a 1.5" x 20' long solid keyed shaft. Three steel lift cables shall be 5/16" x 35' aircraft cable 7x19. Cables shall be rated at 1960 lbs. each at a 5-to-1 safety factor. System shall include an emergency lowering manual override brake, in case of power outage.

40' Load bar shall be connected to 22oz vinyl/polyester super sling able to accommodate up to a 40" diameter mat, with heavy duty straps and fasteners. Standard sling color is black; other colors are available by special request. For safety purposes, sling capacity shall govern the lift capacity of the system. Motors, drive assembly, and all control mechanisms shall be encased in a fire proof safety cover. Warranty shall be 5 years.

Movement control shall be prewired with a furnished electrical key switch wired to an intrinsically safe 24 volt power system with automatic off return and raise/lower legend plate. Wiring and conduit from hoist to key switch and electrical hook-up of unit by others. Approximate unit weight shall be 1,750 lb. (not including mat). Structural support members and wall connections by others to meet building and unit requirements.

For traveling mat lifter, see separate Traveling Mat Lifters Submittal.

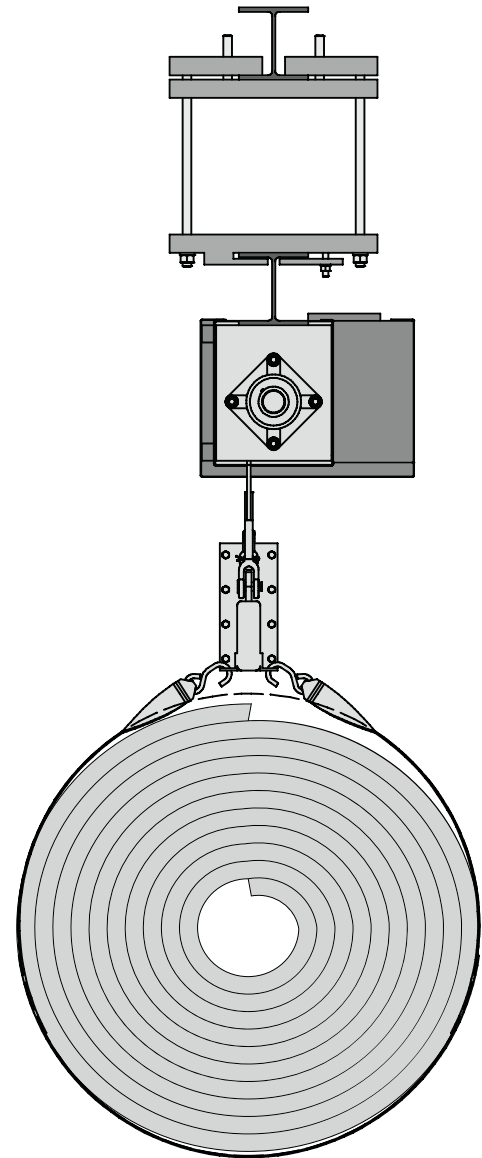

Please provide the following information concerning Mounting Structural Support.

Length: _____ **Elevation:** _____

Type: Steel Other _____

1 (Width): _____

2 (Height): _____

3 (Web): _____

4 (Flange): _____

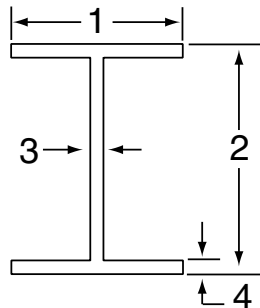

Select Motor Options:

- 208v AC—3-Phase
- 230v AC—3-Phase
- 460v AC—3-Phase



411 S. Pearl St., Spiceland, IN 47385 USA ■ 765-987-7999
www.draperinc.com ■ fax 765-987-7142

Copyright © 2016 Draper Inc. Form SingleMatLifter_502060_Sub16 Printed in U.S.A.

PROJECT: _____

ARCHITECT: _____

CONTRACTOR: _____

SUPPLIER: _____

DATE: _____ REVISED: _____

Single Mat Lifter by Draper

Mounting Options:

Beam Mount

Perpendicular to structural support beams (standard)

Parallel to structural support beams requires optional 502024 Beam Clamp Kit

Wall Mount

requires optional 502023 Wall Bracket Kit (Dimensions below)

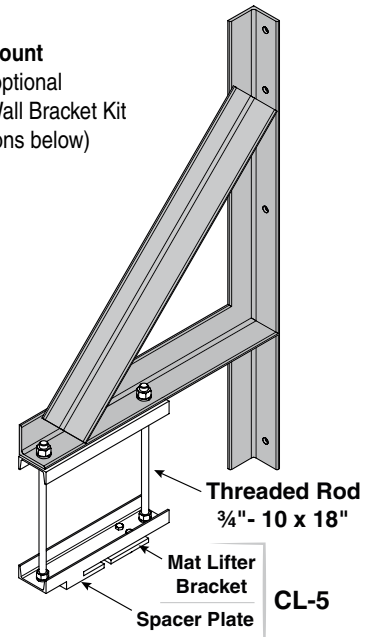
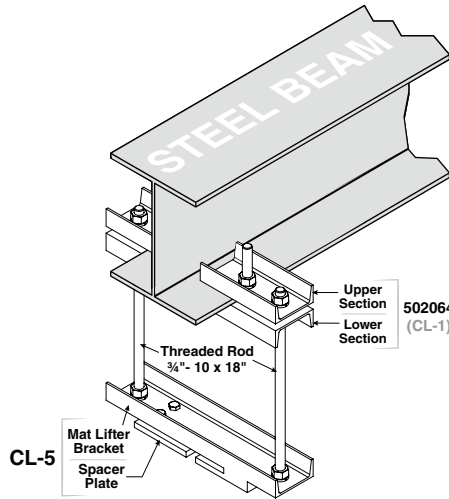
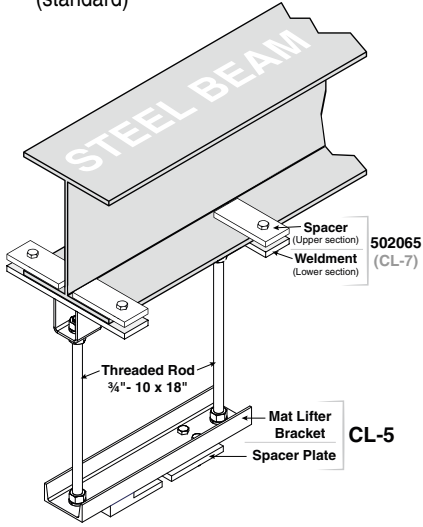

Wall Bracket Dimensions

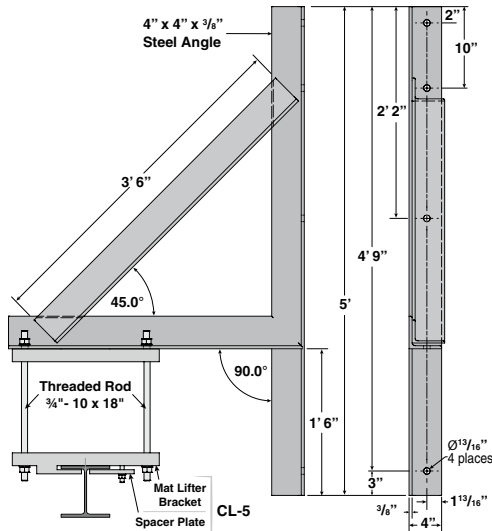

Mat Lifter Dimensions - End View

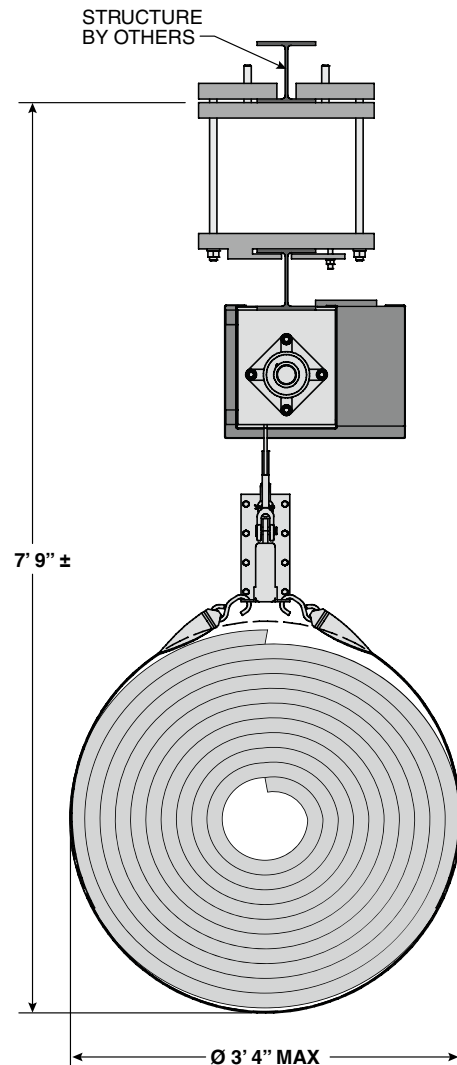

Mounting Bracket to Lift Attachment Detail (Parallel Beam Mount Shown)

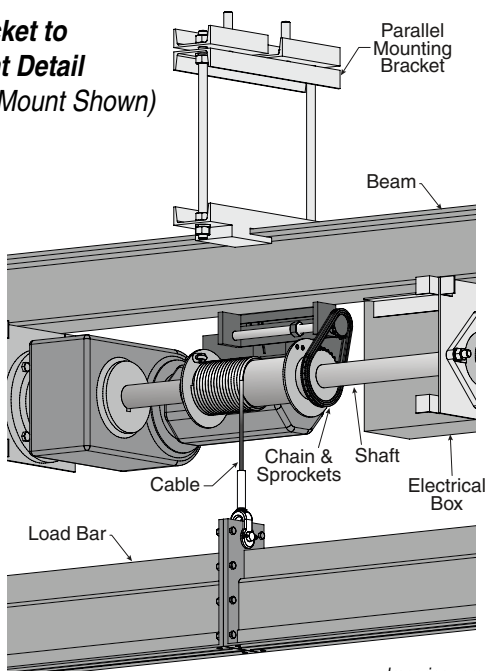

Mat Lifter Dimensions - Continued

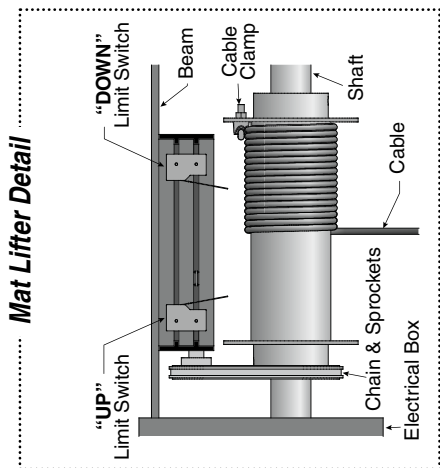

Side View

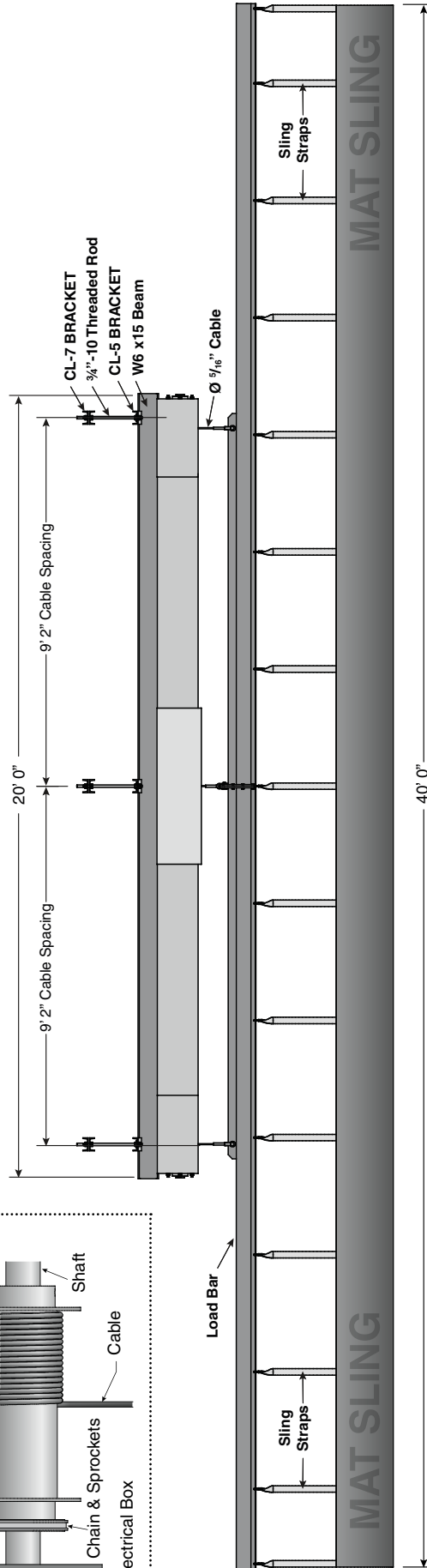

Top View

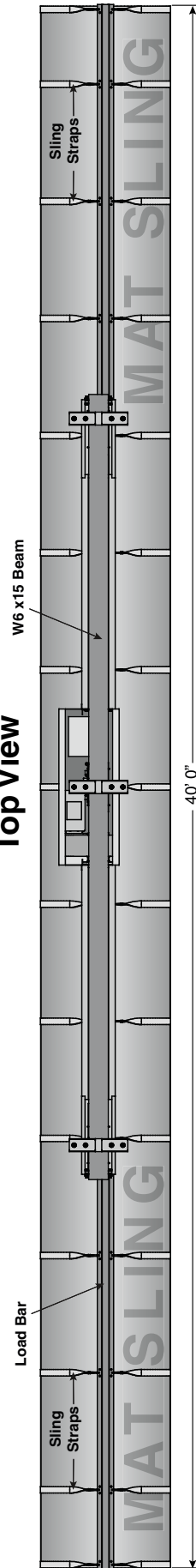

Wiring Diagram

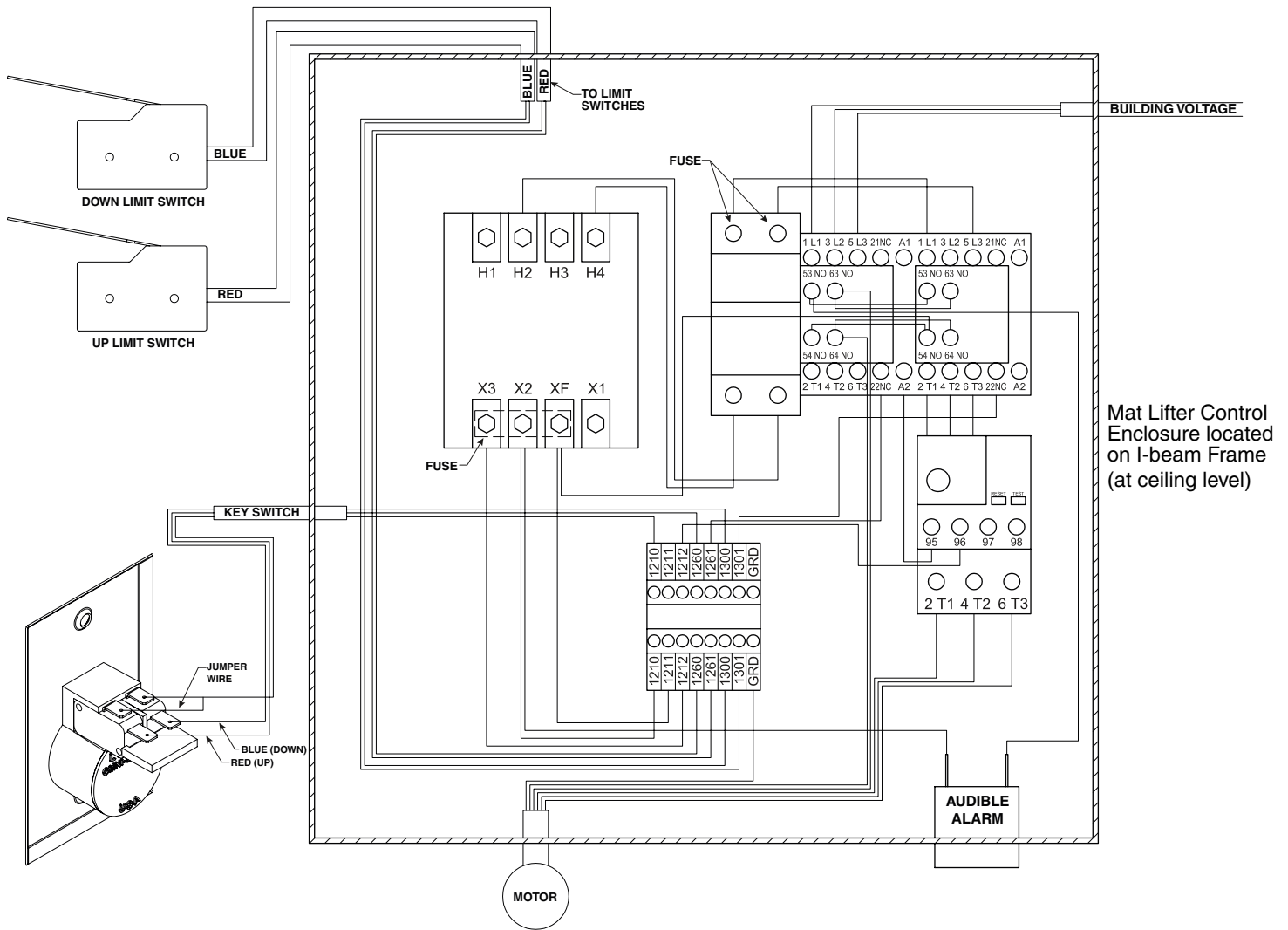

Wiring Notes

Danger: Before installing, removing, inspecting, or performing any maintenance on this unit, the mat lifter shall be de-energized.

Lock and tag in the de-energized position in accordance with ANSI Z244.1.

This unit shall be installed and wired in accordance with ANSI/NFPA 70, National Electrical Code, and all applicable Federal, State, and Local Codes.

Failure to read and comply with this and other warnings may result in serious bodily injury or death and/or property damage.