

C129.030 Standard Gym Divider/Practice Cage Winch

Motorized Winch for use with EZ Fold Basketball Backstops

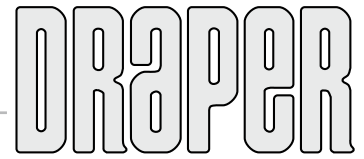

Specifications—

C129.030 Motorized Gym Divider/Practice Cage Winch

Gymnasium Divider Curtain / Practice Cage drive pipe power mechanism shall be model no. C129.030 Motorized Gym Divider/Practice Cage Winch by Draper, Inc, Spiceland, IN.

Drive pipe power mechanism shall operate using of an instant reversing, ¾ HP, 110-120V, 60-cycle, single-phase capacitor style motor with built-in thermal overload protection. Winch to have an oil-filled, precision cast, high-strength metal alloy case that is fully sealed with precision ball bearings and premium gaskets to prevent leaks. Load holding, hardened steel gears and motor combine to produce over 1500 inch pounds of torque at 13.5 RPM. 1-inch keyed output shaft and lightweight, low-profile design allow winch to be used on many different types of drive pipe style curtains including Fold-Ups, Top-Rolls, Roll-Ups and Radius-Folds as well as practice cages.

Remote control operation to include integral limit switches to control upper and lower travel. Provided with three-position, momentary-contact wall switch mounted in a polished switch box cover plate, but can be used with optional wireless remote or group control systems. Key switch or other control is to be located in full view of both sides of curtain or cage during operation.

Draper C129.030 Motorized Gym Divider/Practice Cage Winch is covered by five-year warranty.

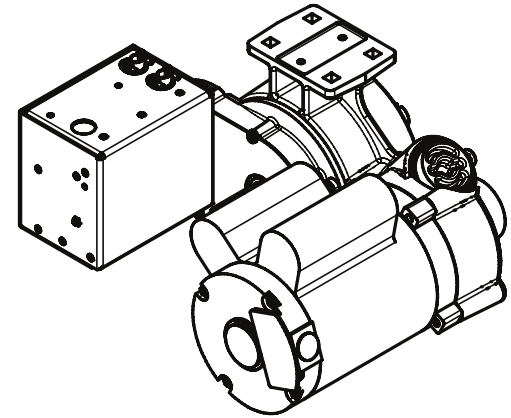

Please check all appropriate selections

Building Structure in Relation to Curtain

- Directly under continuous beam
- Between two beams. Distance between the beams: _____
Distance between curtain and beam: _____
- Right Angle to beams. Spacing between beams: _____

Building Structure for Curtain Support

Beam flange width: _____
Beam flange thickness: _____

Control Options

- Three-position, momentary-contact key switch (standard)
- Wireless Remote Control (see separate submittal document)
- EZ Pad Group Control System (see separate submittal document)
- Smart Gym Group Control System (see separate submittal document)
- 503091 Plug Kit (twist-lock plug, receptacle and 4" box cover plate)



411 S. Pearl St., Spiceland, IN 47385 USA ■ 765-987-7999
www.draperinc.com ■ fax 765-987-7142

Copyright © 2016 Draper Inc. Form StandardDividerWinch_Sub16 Printed in U.S.A.

PROJECT: _____

ARCHITECT: _____

CONTRACTOR: _____

SUPPLIER: _____

DATE: _____ REVISED: _____

Wiring Diagram

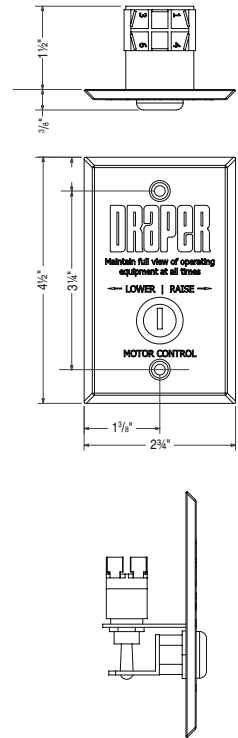
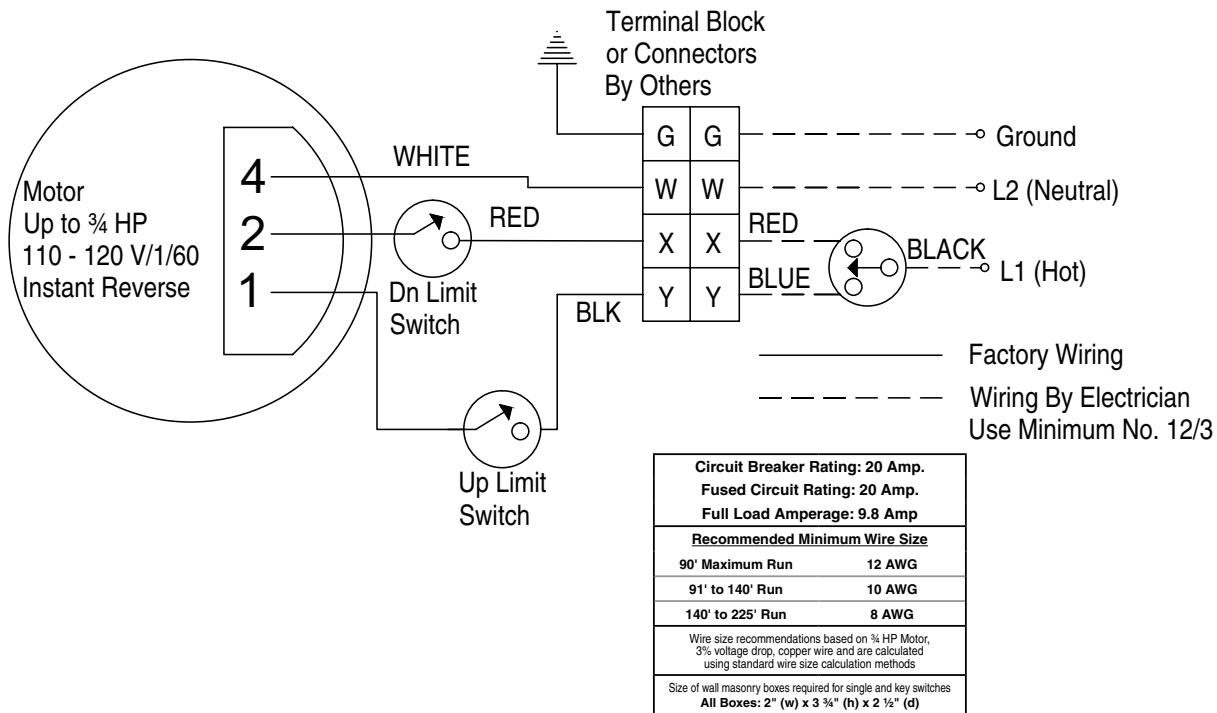

Dimensions

